

# DOMED HIGH BAY - 190WLED



407-478-3759  
www.ilp-inc.com

## DOMED HIGH BAY

### FEATURES

- Cold-forged aluminum heat sink
- 14" aluminum reflector option
- 16" or 22" acrylic diffuser option
- Multiple dimming and sensor options
- Multiple mounting options
- ETL Listed
- 5000K (only)
- 5 year warranty
- 1-10V Dimmable Driver
- DesignLights Consortium® Qualified Luminaire



### SUITABLE APPLICATIONS

- Warehouses
- Distribution Centers
- Manufacturing Plants
- Gymnasiums

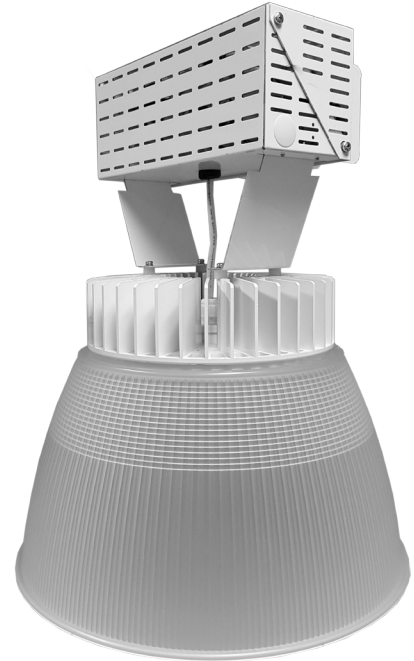

Shown with 16" Acrylic Diffuser

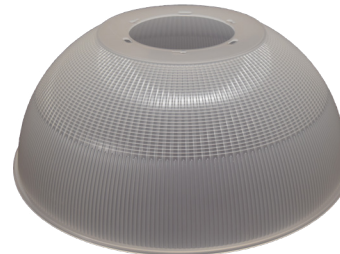

22" Acrylic Diffuser



Aluminum Reflector

LED SYSTEMS INFO	BASE	REFL90	AD16	AD22
Calculated L <sub>70</sub> (TM-21)	>100K	>100K	>100K	>100K
Delivered Lumens	23,710 lm	20,800 lm	22,925 lm	23,111 lm
Total Input Watts	183 W	183 W	183 W	183 W
Luminaire Efficacy Rating (LER)	130 lm/W	114 lm/W	125 lm/W	126 lm/W
Correlated Color Temperature (CCT)	5000K	5000K	5000K	5000K
Color Rendering Index (CRI)	>70	>70	>70	>70
Maximum Ambient Temperature	130°F	130°F	130°F	130°F
Minimum Ambient Temperature	-40°F	-40°F	-40°F	-40°F
Universal Driver	120-277 V	120-277 V	120-277 V	120-277 V

LED System data above based on DHB-190WLED-UNIV-50, DHB-190WLED-UNIV-50-REFL90, DHB-190WLED-UNIV-50-AD16 and DHB-190WLED-UNIV-50-AD22  
LED Lumen Maintenance Estimates based on TM-21 projections for the light source at 25°C ambient.

### ORDERING GUIDE:

Series	Watts	Driver	Color	Options
DHB Domed High Bay	190WLED	UNIV 120-277 V Driver	50	<b>REFL90</b> 14" Aluminum Reflector <b>AD16</b> 16" Frosted Acrylic Diffuser <b>AD22</b> 22" Frosted Acrylic Diffuser <b>CORDx</b> Cord (x = ft) <b>WC16</b> 16" Wire Cage <b>WC22</b> 22" Wire Cage <b>FIOS</b> On/Off Occupancy Sensor Installed <b>FIOS/PC</b> On/Off Occupancy Sensor w/ Photocell <b>USBD</b> User Select Bi-level Dim w/ Occ. Sensor <b>BDxx</b> Preset Bi-Level Dim Sensor (xx=%eg.20,30) <b>HOOK</b> Cast Iron Hook For Single Point Mounting <b>HUB 3/4</b> Conduit Hub 3/4" For Pendant Mounts <b>HB-XX-18Y-PAD</b> Y-Toggle Cable System (XX = in) <b>LEDBB</b> LED Battery Backup (may reduce max ambient) <b>SD480*</b> 480V Step Down Transformer

# DOMED HIGH BAY - 190WLED

## DOMED HIGH BAY

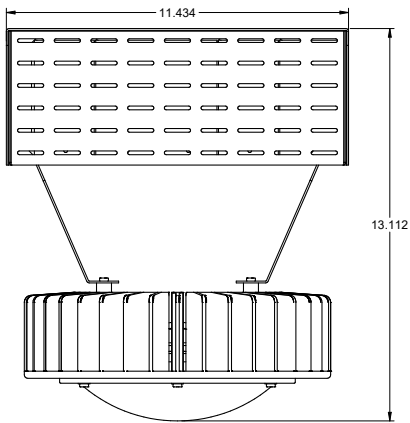

Front View

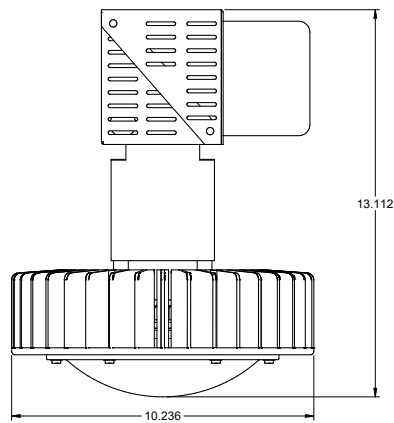

Side View

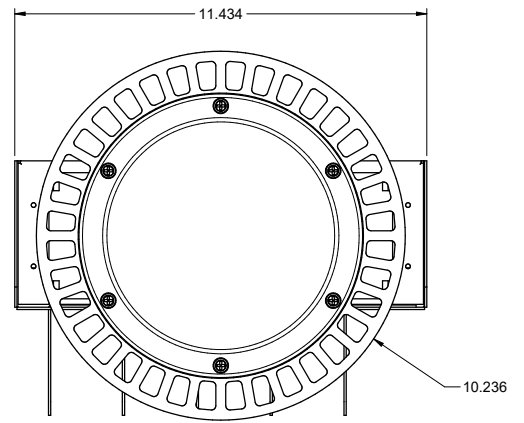

Bottom View

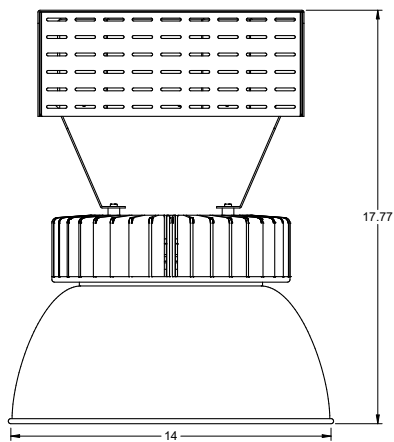

**REFL90**

14" Aluminum Reflector

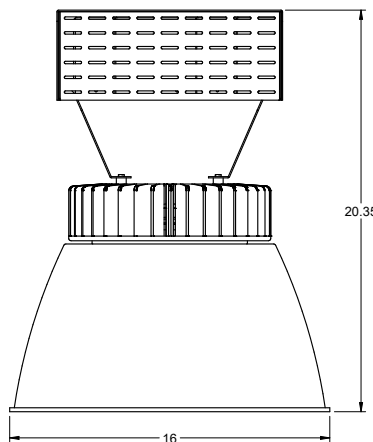

**AD16**

16" Frosted Acrylic Diffuser

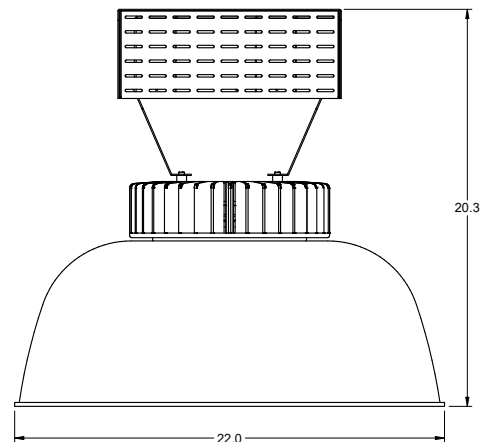

**AD22**

22" Frosted Acrylic Diffuser

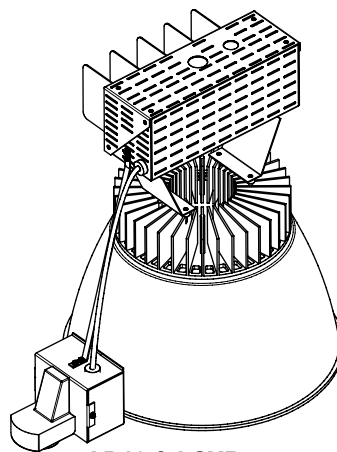

AD16 & LSR sensor

## MOUNTING OPTIONS

- **HOOK** - Cast iron hook for single point mounting
- **Y-Toggle Cable Kit** - Includes two adjustable cable hangers
- **Conduit Hub** - Conduit hub  $\frac{3}{4}$ " for pendant mounts



**HOOK**

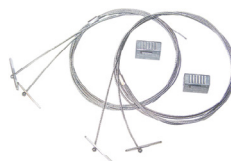

**HB-XXX-PAD**



**HUB  $\frac{3}{4}$ " CONDUIT**

# DOMED HIGH BAY - 190W LED

## PHOTOMETRIC REPORTS

### DHB-190WLED-UNIV-50

#### SUMMARY DATA

HEMISPHERES TESTED:	BOTH
EFFICIENCY (Downlight):	97.3 %
EFFICIENCY (Uplight):	2.7 %
CIE CLASSIFICATION:	DIRECT
SPACING CRITERION (0-Deg.):	1.22
LUMENS:	22529.84
INPUT WATTS:	182.74

#### CANDELA PLOT

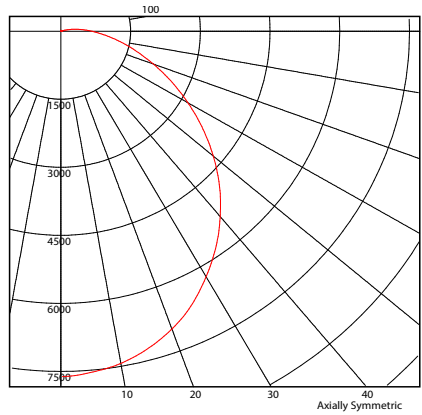

Photometric values based upon tests performed in compliance w/ LM-79. Download IES files at [www.ilp-inc.com](http://www.ilp-inc.com)

### DHB-190WLED-UNIV-50-REFL90

#### SUMMARY DATA

HEMISPHERES TESTED:	BOTH
EFFICIENCY (Downlight):	99.5 %
EFFICIENCY (Uplight):	0.5 %
CIE CLASSIFICATION:	DIRECT
SPACING CRITERION (0-Deg.):	1.15
LUMENS:	19899.97
INPUT WATTS:	182.67

#### CANDELA PLOT

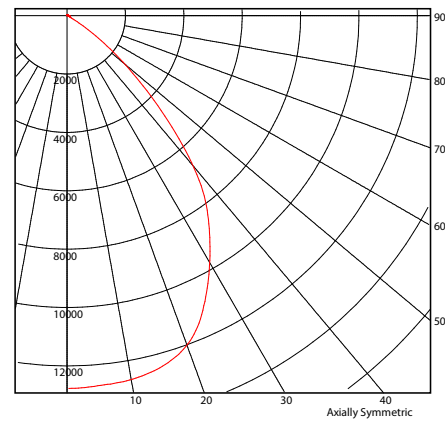

Photometric values based upon tests performed in compliance w/ LM-79. Download IES files at [www.ilp-inc.com](http://www.ilp-inc.com)

### DHB-190WLED-UNIV-50-AD16

#### SUMMARY DATA

HEMISPHERES TESTED:	BOTH
EFFICIENCY (Downlight):	86.4 %
EFFICIENCY (Uplight):	13.6 %
CIE CLASSIFICATION:	SEMI-DIRECT
SPACING CRITERION (0-Deg.):	1.17
LUMENS:	21831.56
INPUT WATTS:	182.667

#### CANDELA PLOT

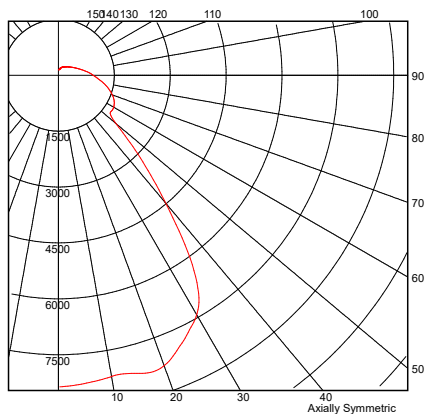

Photometric values based upon tests performed in compliance w/ LM-79. Download IES files at [www.ilp-inc.com](http://www.ilp-inc.com)

### DHB-190WLED-UNIV-50-AD22

#### SUMMARY DATA

HEMISPHERES TESTED:	BOTH
EFFICIENCY (Downlight):	87.3 %
EFFICIENCY (Uplight):	12.7 %
CIE CLASSIFICATION:	SEMI-DIRECT
SPACING CRITERION (0-Deg.):	1.12
LUMENS:	21862.76
INPUT WATTS:	182.59

#### CANDELA PLOT

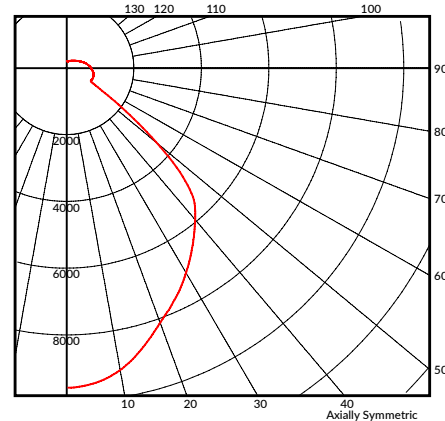

Photometric values based upon tests performed in compliance w/ LM-79. Download IES files at [www.ilp-inc.com](http://www.ilp-inc.com)