

Project Name:

Part Number:

Type:

TWIN BULLHORN

S2-S36-2, S2-S36-3, S2-S36-4



407-478-3759
www.ilp-inc.com

FEATURES

- Twin bullhorn luminaire mounting bracket for wood, steel, or concrete poles
- Body is steel tube constructed from A500 Grade B Steel
- Designed to slip fit onto 2-3/8", 2-7/8" and 4" vertical tenons
- Assembled removable cap with mounting hardware provided standard
- EPA: 1.0
- Weight: S2-S36-2 = 20 lbs, S2-S36-3 = 22 lbs, S2-S36-4 = 25 lbs
- Max luminaire weight per arm: 100 lbs
- Coated with a durable polyester powder coat finish to withstand extreme weather changes without cracking or peeling (Consult Factory for custom colors)
- 5-Year warranty



COMPATIBLE WITH

- AL
- CFS
- CFM
- SAS
- SAM
- VFM
- VFL
- VFX
- VAS
- VAM

ORDERING GUIDE:

SERIES	SPACING	TENON	FINISH
S2	S36	2 2-3/8"	BRZ Bronze
		3 2-7/8"	BLK Black
		4 4"	SLV Silver
			WHT White

LINE DRAWINGS

PART #	DIMENSION A	DIMENSION B
S2-S36-2	2.48"	5"
S2-S36-3	3.08"	6"
S2-S36-4	4.25"	6 7/16"

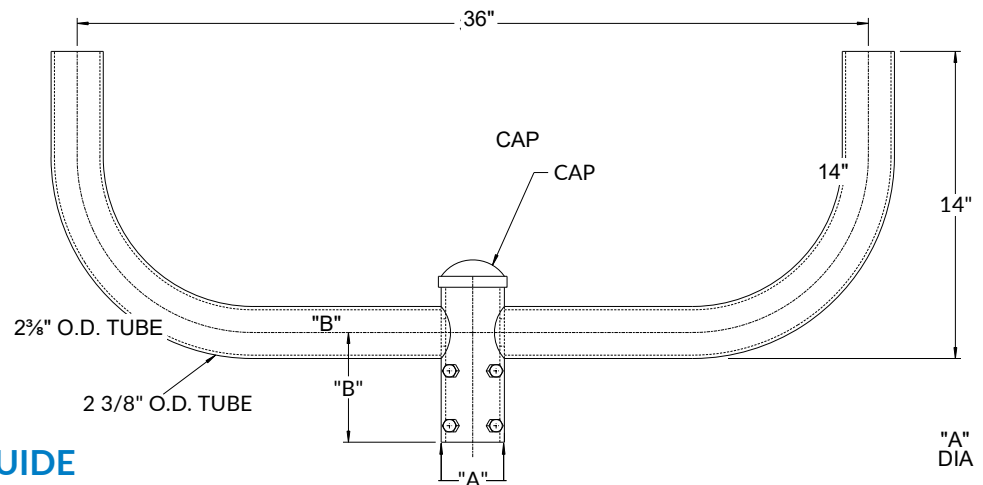

FACTORY SELECT COLOR GUIDE

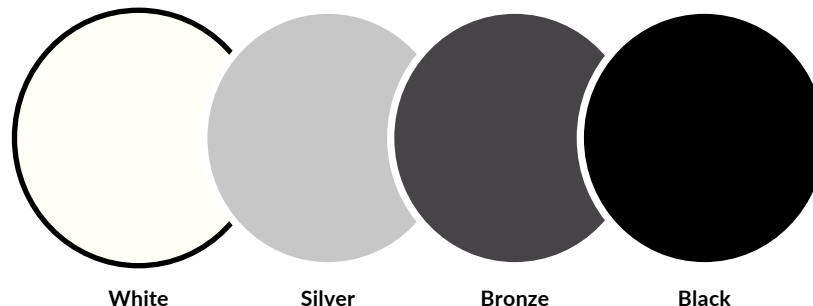

COLORS SHOWN ABOVE ARE TO BE USED AS REFERENCE, NOT EXACT MATCH.
PLEASE REQUEST PAINT CHIPS FOR EXACT MATCH.