

Project Name:

Part Number:

Type:

# WALL TENON BRACKET



407-478-3759  
www.ilp-inc.com

## FEATURES

- Single luminaire 2-3/8" tenon wall mounting bracket
- Body is steel tube constructed from A500 Grade B Steel
- Alternate arm lengths available, consult factory
- Weight: 7 lbs
- Max luminaire weight: 90 lbs
- Coated with a durable polyester powder coat finish to withstand extreme weather changes without cracking or peeling (Consult Factory for custom colors)
- 5-Year warranty

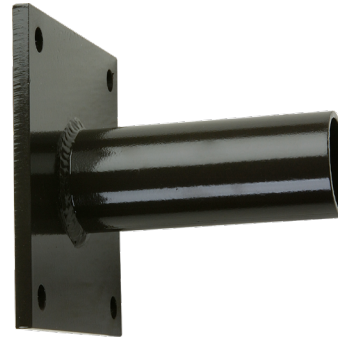

## COMPATIBLE WITH

- AL
- SAS
- SAM
- VFM
- VFL
- VFX
- VAS
- VAM

## ORDERING GUIDE:

SERIES	TENON	FINISH
VT2	4 4"	<b>BRZ</b> Bronze
	6 6"	<b>BLK</b> Black
		<b>SLV</b> Silver
		<b>WHT</b> White

## LINE DRAWINGS

PART #	DIMENSION A
VT2-4	4"
VT2-6	6"

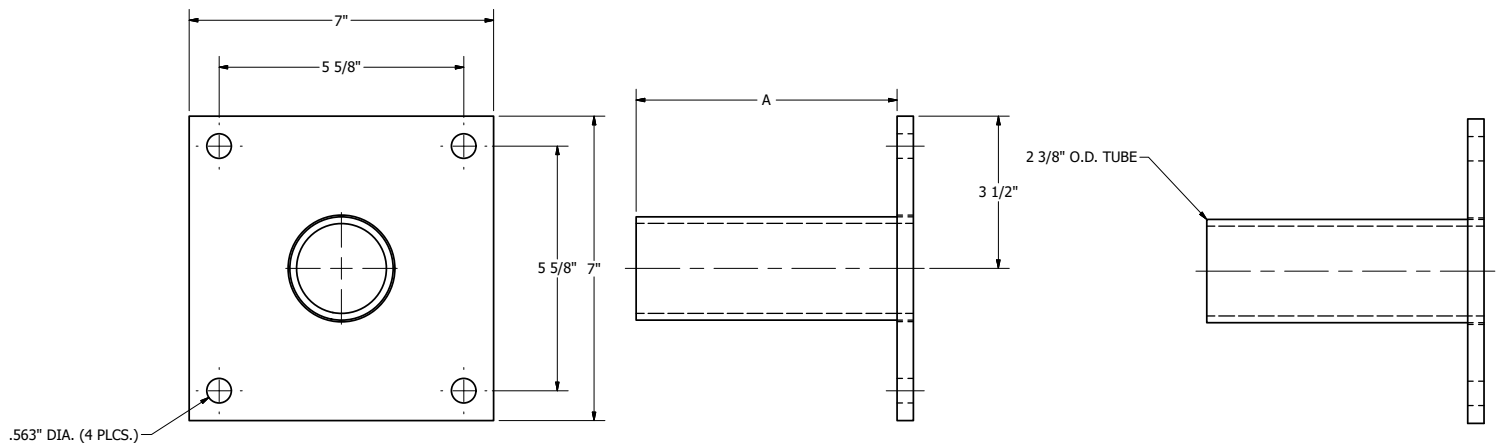

## FACTORY SELECT COLOR GUIDE

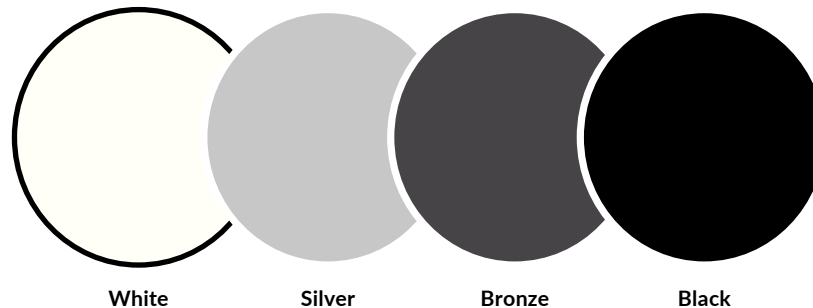

COLORS SHOWN ABOVE ARE TO BE USED AS REFERENCE, NOT EXACT MATCH.  
PLEASE REQUEST PAINT CHIPS FOR EXACT MATCH.