



BAA Buy American Act

TAA Trade Agreement Act

PRODUCT LINE UP



BAA Buy American Act

TAA Trade Agreement Act



ILLUMUS PROUDLY COMPLIES WITH THE BUY AMERICAN ACT

ILLUMUS, powered by GREEN CREATIVE and ILP, has built a reputation for creating consistent and reliable lighting products by hard-working Americans. We continue to serve all our customer's needs with American ingenuity, built by American hands that are homegrown in Sanford, Florida, USA.

The Buy American Act (BAA) of the American Recovery and Reinvestment Act (ARRA) "restricts the purchase of supplies that are not domestic end products, for use within the United States", and uses a two-part test to define a domestic end product:

- The product must be manufactured in the United States
- The cost of the domestic components must exceed 50% of the total cost of components.

A good or service is Trade Agreement Act (TAA) compliant if manufactured or substantially transformed in the United States or manufactured in a TAA-designated country.

All the ILLUMUS products listed in this brochure meet the stringent requirements set by BAA under the ARRA act or TAA and proudly bear the logos below on all marketing collateral, making it easy to recognize which products comply. When purchasing a BAA or TAA product, always verify that they are compliant.



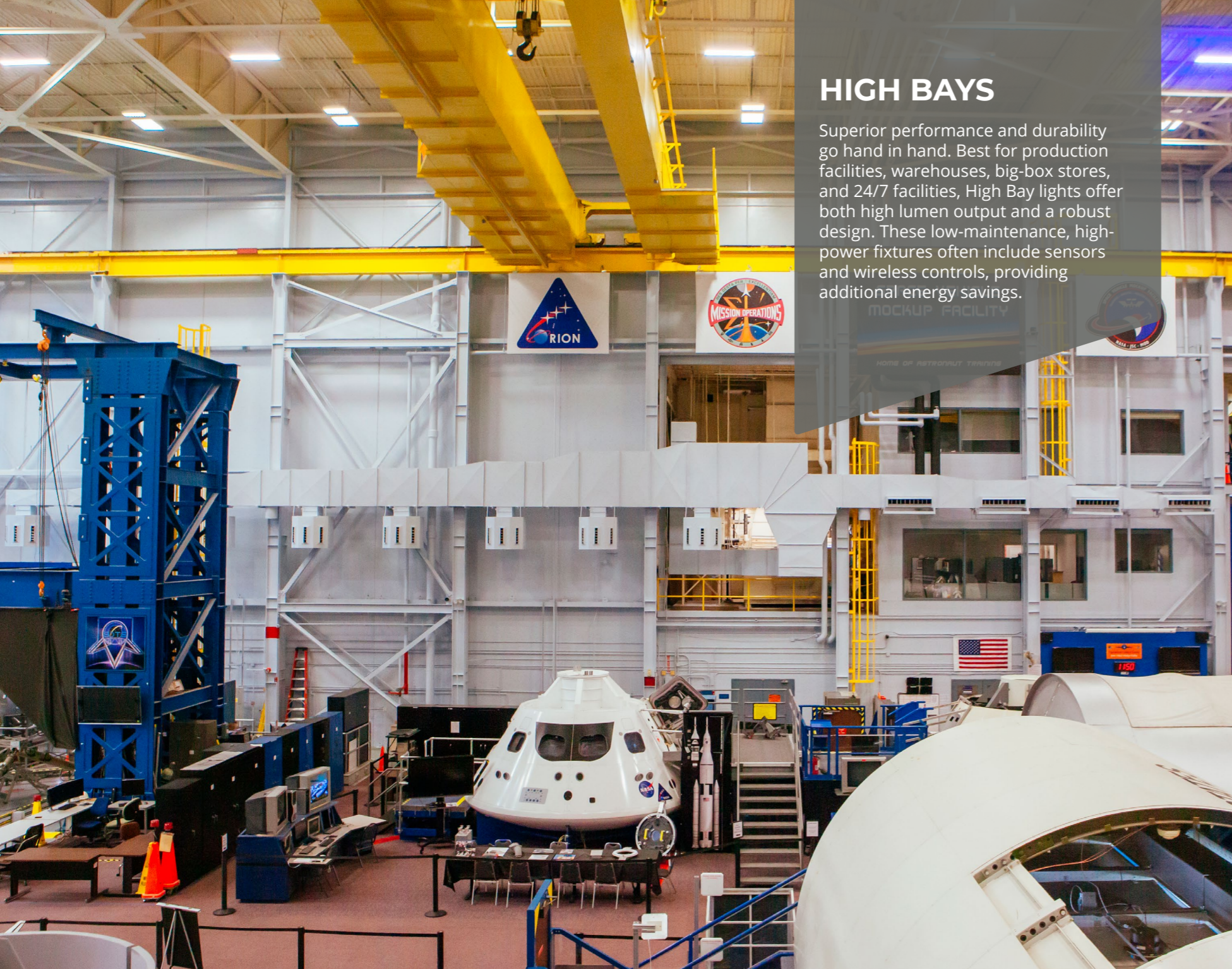

HIGH BAYS

Superior performance and durability go hand in hand. Best for production facilities, warehouses, big-box stores, and 24/7 facilities, High Bay lights offer both high lumen output and a robust design. These low-maintenance, high-power fixtures often include sensors and wireless controls, providing additional energy savings.

ENDEAVOUR HIGH BAY (EDV 2.0)



Endeavour 2.0 is the linear high bay of the future. Sturdy - but sleek, it features an aluminum body with curved end caps in white, black or custom finishes to suit even the most unique project aesthetics. Endeavour 2.0 is built to withstand high abuse applications with an IK10 impact rating - the highest impact rating. Endeavour 2.0's uplight option provides enhanced full room illumination, while the high performance narrow and wide distribution optics provide superior horizontal or vertical light levels with excellent uniformity.



ROUND LOW BAY (UFO-LB)

- Visually comfortable illumination
- 10% uplight reduces cave effect
- Sensor & wireless controls ready



GRID FRAME HIGH BAY (GH)

- High performance recessed high bay
- Various lens options for aesthetics
- 2x2' & 2x4' sizes



INDIRECT HIGH BAY (PHB-TC)

- Inverted mounting for indirect distribution
- 100% glare reduction
- 75,000 - 97,000 lumen packages



VAPOR TIGHTS AND KITS

Vapor tights are sealed and gasketed luminaires that are best used in extreme environments. Though these fixtures are often found around wet locations or in freezers and refrigerated areas, they are suitable for any industrial or commercial application where safety and protection are a must.

BLIZZARD HIGH BAY (BL)

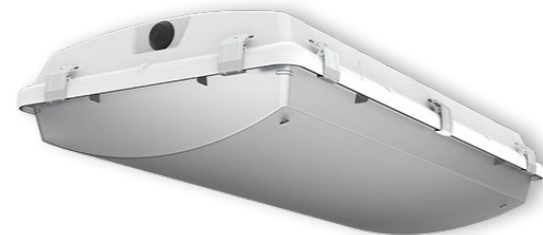

BL Series is an industry leading luminaire designed for applications requiring a robust, durable, sealed and gasketed construction for extreme environments. The NSF listed fiberglass enclosure is easy to service and clean, ideal for maintaining a safe environment for food and beverage processing. With an enhanced feature set including industry leading ambient operating temperatures, best in class distribution options, extremely high efficiency, wide lumen range, and multiple mounting options, the BL series is the prominent choice for nearly any high bay application.



AMAZON VAPOR TIGHT (WTZ)

- Most comprehensive sealed vapor tight in the market
- Durable construction for abusive environments
- Low profile 2', 4' & 8' housings



VAPOR TIGHT HB RETROFIT (BLR)

- Easy upgrade to LED
- Long list of compatible luminaires
- Installs in 4' housing in 5 mins or less



X SERIES VAPOR TIGHT (WTX)

- Sealed & gasketed vapor tight
- Unique light bar technology
- Slim profile 4' & 8' lengths



VAPOR TIGHT RETROFIT KIT (VTR)

- Easy upgrade to LED
- Long list of compatible luminaires
- Installs in 4' or 8' housing in 5 mins or less



TROFFERS AND KITS

The preferred choice for schools, offices, and a variety of commercial applications, LED troffers provide enhanced aesthetics while optimizing energy savings. These sleek, solid-state luminaires are perfect for new construction or retrofit applications.

VOLUMETRIC TROFFER (VOLA)

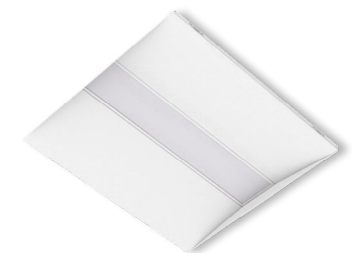

FLAT VOLUMETRIC TROFFER (FLT)

- Flat lens volumetric design
- Delivers smooth uniform illumination
- Tamper resistant design



VOLUMETRIC RETROFIT KIT (LANCE)

- Architecturally designed volumetric troffer retrofit kit
- High efficacy - up to 151 lm/W for enhanced energy savings
- Advanced controls options for asset tracking



FLAT TROFFER RETROFIT (FLTR)

- Enhanced aesthetics troffer retrofit kit
- Delivers smooth uniform illumination
- Optional tamper resistant design



TROFFER RETROFIT KIT (RTR)

- One-piece construction troffer kit
- Designed to replace prismatic & parabolic troffer light engines
- Wireless controls options



VOLA is designed for rigidity, durability and ease of installation while providing maximum performance and improved aesthetics. With an exceptionally robust offering of lumen outputs, sizes and options, VOLA is designed for a multitude of applications.



STRIPS AND KITS

LED Strips offer a sleek and versatile solution for new construction or retrofit projects. These fixtures can be mounted in continuous rows or as stand-alone luminaires and are simple to install. Various lengths, features and aesthetics are available, providing optimal flexibility when needed most.

DISCOVERY LINEAR STRIP (DSC)



VARI LINEAR RETROFIT (VLR)

- Highly configurable & adaptable BAA linear retrofit
- 4ft & 8ft lengths available
- 8 lumen packages ranging 2,000 - 12,000



The Discovery Linear Strip is a highly configurable BAA spec grade strip luminaire. The injection-molded endcap smooth designs have no visible fasteners. The luminaire comes in three sizes (2', 4', 8'), vast lumen range and four different mounting options, catering to your project aesthetics, functionality, and flexibility. Available with a variety of compatible wireless grouping controls in order to cater to your space and maximize energy savings in the way you want.



WRAPS & STAIRWELL

Wrap lighting is perfect for both high-traffic areas like workspaces and common rooms, as well as low-traffic areas such as storage rooms, restrooms, and stairways. These luminaires are ideal for spaces with unique designs or uncommon angles, where operators need to maximize light output in key locations.

CURVED WRAP (SQ)



The SQ wrap's modern sleek curved profile provides smooth uniform illumination with an enhanced feature set. Maximize scalability with its various lengths, lumen range, controls options and mounting options for surface, pendant and continuous row applications.

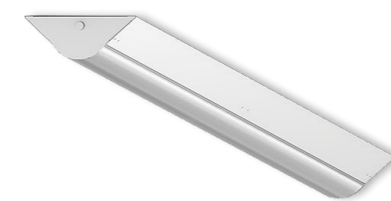

CURVED WIDE BASE WRAP (SQWB)

- Covers existing wide wrap footprints
- Suitable for installing in continuous runs
- 2', 4' & 8' lengths



NARROW WRAP (FNW)

- Narrow & sleek 9" width design
- Molded end cap for polished appearance
- 4ft & 8ft lengths



WIDE WRAP (FWW)

- 13" width covers existing wrap footprints
- Molded end cap for polished appearance
- 4ft & 8ft lengths



SHALLOW WRAP (FWS)

- General purpose shallow wrap
- Prismatic wraparound lens
- 4ft & 8ft lengths



CAVERN STAIRWELL (CV)

- Specification grade robust design
- Bluetooth programmable ultrasonic sensor
- Emergency integration achieves life safety requirements



TLED KITS & FIXTURES

LED tubes are the simplest retrofit. Often the most economic choice, LED tubes are suitable for any application where fluorescent tubes are already in place. Users benefit from substantial energy savings over time and reduced maintenance and replacement costs.

STRIP FIXTURE (FST T8 TLED)



STRIP RETROFIT KITS FROM ILP ARE ENGINEERED TO EASILY CONVERT EXISTING STRIP WITH TLEDs. MULTIPLE BRACKETS AND REFLECTOR OPTIONS ARE AVAILABLE TO MATCH OR ENHANCE EXISTING STYLES. PRE-WIRED KIT OPTIONS FOR EITHER SINGLE ENDED OR DOUBLE ENDED LED TUBES WITH SHUNTED OR NON-SHUNTED SOCKETS OPTIONS ARE AVAILABLE FOR OPTIMIZED INSTALLATION CONVENIENCE. THE PRODUCTS ARE ETL LISTED FOR DAMP LOCATIONS, AND GUARANTEED WITH OUR 5-YEAR WARRANTY.



TROFFER RETROFIT KIT (RTR T8 TLED)

- Easily converts existing troffer with TLED's
- 2x2 & 2x4 sizes
- White & aluminum reflector options



STRIP RETROFIT KIT (RST T8 TLED)

- Easily converts existing strip with TLED's
- Multiple bracket & reflector options to match or enhance existing styles
- 4ft & 8ft lengths

WRAP FIXTURE (FNW & FWW T8 TLED)

- Pre-wired TLED ready wrap fixtures
- Molded end cap for polished appearance
- Narrow 9" & wide 13" width designs

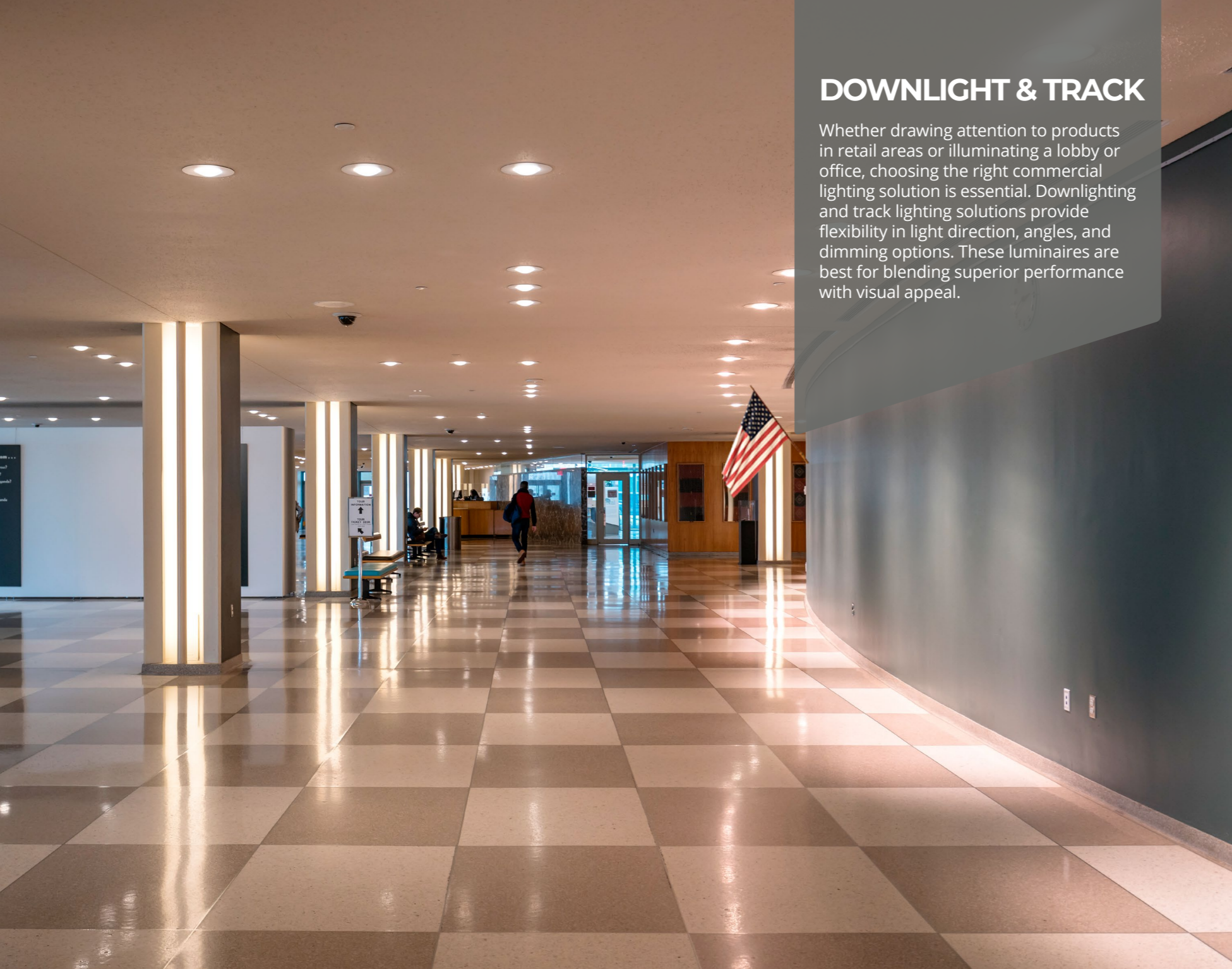

DOWNLIGHT & TRACK

Whether drawing attention to products in retail areas or illuminating a lobby or office, choosing the right commercial lighting solution is essential. Downlighting and track lighting solutions provide flexibility in light direction, angles, and dimming options. These luminaires are best for blending superior performance with visual appeal.

NYX NEW CONSTRUCTION



NYX
SERIES

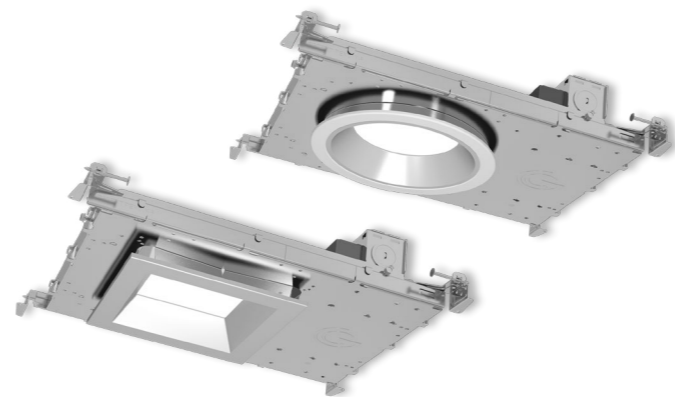

With integrated SelectDrive, SelectKelvin and DualDim technologies, abundant options of field installable accessories, and unique compact design, NYX revives customized downlighting design for any new construction project.



SPECFIT NEW CONSTRUCTION

- Specification grade lighting performance
- Adjustable lumen output up to 5,000lm
- TRUE CHROMA options for superior color accuracy



ORBIT TRACK

- Specification grade & performance design
- Spot, narrow & flood interchangeable optics
- Industry leading lumen selectable output range



PXCYL CYLINDERS

- Elegant design with wide application use
- Five interchangeable beam angles
- Industry leading lumen selectable output up to 5,000lm



SOL TRACK HEAD

- Integrate durable track housing with upgradable LED PAR lamps
- 2-plane gimbal design
- Options of H and J type adapters



OUTDOOR

From gardens to parking lots, outdoor lighting applications are as diverse as the products that serve them. Outdoor lights not only offer safety and security but can also provide visual comfort. Area lights and vapor tights illuminate parking areas or corridors, while wall packs and bollards illuminate pathways and building facades.

SKYLINE AREA & FLOOD (SA/SF)



The Skyline's sleek aesthetic makes it perfectly-suited for warehouse area & flood applications. Designed for both new construction and retrofit, the Skyline provides a one-for-one solution for replacing legacy metal halide or high pressure sodium luminaires. Priced for payback, it's cost effective die-cast aluminum housings comes in 3-sizes and DLC Premium efficacies, making it the best choice for low acquisition cost and high energy savings. The highly configurable Skyline provides superior illumination, reliability, and ease of installation, exceeding most application requirements.



FULL CUTOFF WALL PACK (WPC)

- 2 sizes with multiple optical distributions
- Legacy aesthetic with next generation performance
- Sensor & wireless controls ready



BOLLARDS (BLDT & BLFT)

- 6" flat or dome top bollards
- Value driven, quick ROI
- Multiple beam patterns



VAPOR TIGHT (WTZ)

- Sealed & gasketed vapor tight
- Durable construction for abusive environments
- 2', 4' & 8' lengths



ROUND PARKING GARAGE (UFO)

- Visually comfortable illumination
- 10% uplight reduces cave effect
- Sensor & wireless controls ready



POLES & BRACKETS

- Straight square steel poles up to 40'
- Multiple bullhorn, wall, and wood pole mounting options
- Adapters for every site scenario

BAA Buy American Act
TAA Trade Agreement Act
**PRODUCT
LINE UP**



GREENCREATIVE

www.greencreative.com



www.ilp-inc.com

An ILLUMUS Brand

www.ILLUMUS.com