



VPAN BACK-LIT PANEL

INSTALLATION INSTRUCTIONS

⚠ CAUTION

PLEASE READ INSTRUCTIONS BEFORE COMMENCING INSTALLATION AND RETAIN FOR FUTURE REFERENCE.
Electrical products can cause death or injury, or damage to property. If in any doubt about the installation or use of this product, consult a competent electrician.

⚠ WARNING

- Risk of Fire, Electrical Shock, Cuts or other Casualty Hazards - This product must be installed in accordance with the applicable installation code by a person familiar with the construction and operation of the product and the hazards involved. The light source contained in this luminaire shall only be replaced by the manufacturer or his service agent or a similar qualified person.
 - Risk of Fire, Electrical Shock - Disconnect power at the source before installation, inspection or removal.
 - Risk of Fire - Minimum 90°C supply conductors.
 - Risk of Burn - Disconnect power and allow fixture to cool before handling or servicing.
 - Risk of Personal Injury - Due to sharp edges, handle with care.
- Failure to comply with these instructions may result in death, serious bodily injury and property damage.

⚠ CAUTION

NOTICE: Read carefully before installing fixture. Retain for future reference.
NOTICE: Ground screw provided in proper location. Do not alter, relocate, or remove wiring, power supply, or any other electrical component.
NOTICE: Fixture may become damaged and / or unstable if not installed properly. Do not use if product is damaged.
NOTICE: Suitable for damp or dry locations only.

General Wiring Diagram:

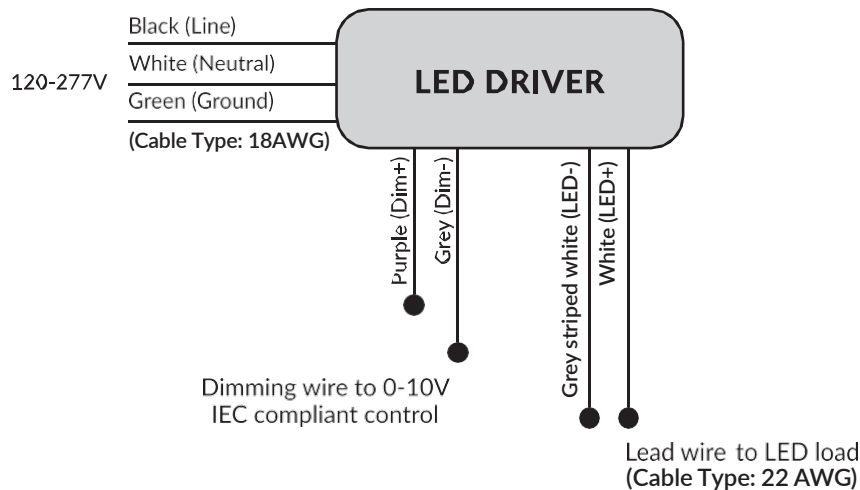

NEMA "G" (Grid) fixture

The VPAN Back-Lit Panel is designed to fit securely into a standard NEMA Type "G", 1" nominal T-bar system. Consult the factory for use with other grid systems.

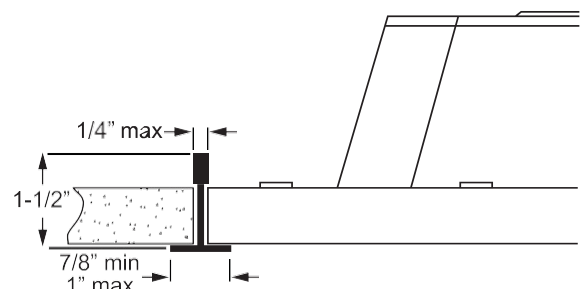



VPAN BACK-LIT PANEL

INSTALLATION INSTRUCTIONS

Follow the steps below to install the fixture(s) into a NEMA Type "G" ceiling system.

Always turn off the power supply from main circuit breaker first!

Installation Steps:

- Pass fixture through the grid at a 45 degree angle and lay fixture into the grid. (Figure 1)
- Use earthquake clips to secure the fixture to the ceiling structure for added stability. Orient 4 tabs on back of the fixture over T-Grid by bending tabs up 90 degrees perpendicular to back of fixture. Next bend tabs 90 degrees towards T-Grid frame. (Figure 2)
- Use safety cables (not included) for additional retention to ceiling system. Use a "#8x1/4" sheet metal screw to fasten fixture to T-Grid and use a hanger wire to tie off appropriately in accordance with local building codes (screws and hanger wires not included). (Figure 2)
- Remove appropriate knockout(s) for power supply wiring.
- Use open knockout to bring in supply wire. Attach the product ground wire with the supply ground wire, the black wire to the black supply wire, and the white wire to the white supply wire.
- Install dimming wires by connecting the low voltage 0-10V dimmer switch. (Figure 3)
- To clean fixture use a lightly water moisten cloth and wipe the lens. Do not use chemicals on the lens as this could cause damage.
- Tuck all wires and wire nuts into the fixture junction box and replace cover. Turn breaker on. Use wall switch to verify light turns on.

Figure 1

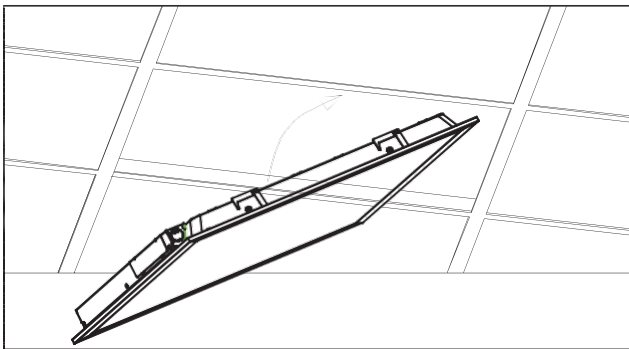
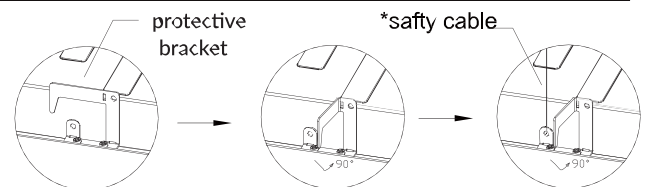
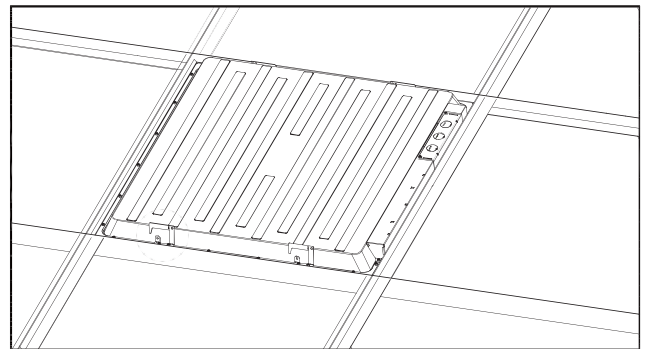
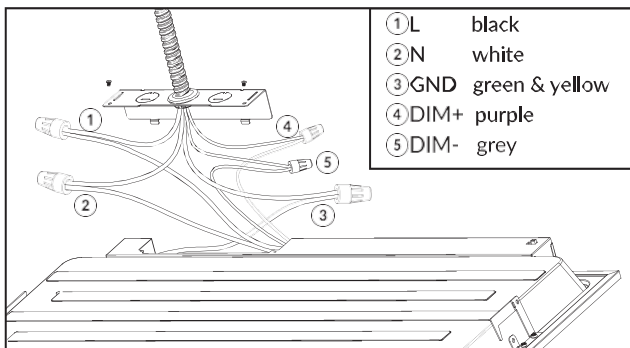

Figure 2



*Put safety cable through hole of bracket and affix it onto the brackets.

Figure 3





VPAN BACK-LIT PANEL

INSTALLATION INSTRUCTIONS

Additional Accessories - Surface Mount

- Position the surface mount box at desired mounting location for the fixture and run necessary wires through one of the knockouts on back of the surface mount box. Use a cordless drill or screwdriver to secure the luminaire to the ceiling surface using the appropriate mounting hardware. This kit is designed to be used with a maximum of 3/16" diameter hardware.(Figure 1)
- Slide fixture partway into the surface mount box. Remove the access plate from the rear of the driver box and make wiring connections according to state and federal regulations.(Figure 2)
- Slide fixture fully into the surface mount enclosure. Use the provided hardware to screw the end cap to the surface mount box to complete installation. (Figure 3)

Figure 1

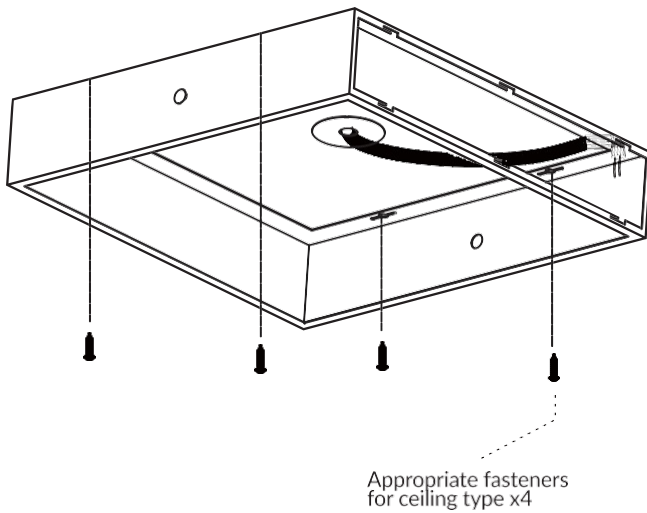

Figure 2

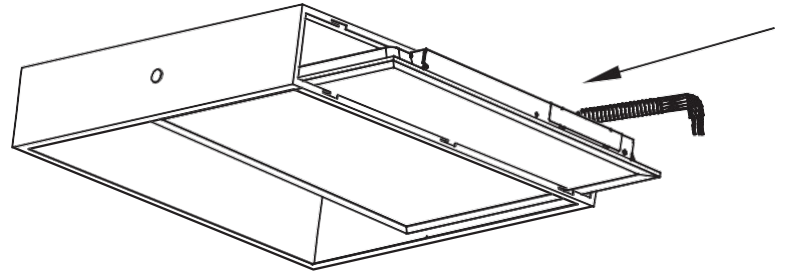
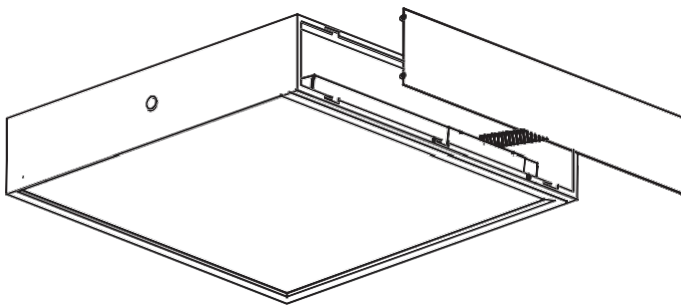

Figure 3





VPAN BACK-LIT PANEL

INSTALLATION INSTRUCTIONS

Additional Accessories – SEK Suspension Installation Instructions

- Slide fixture partway into the surface mount box. Remove the access plate from the rear of the driver box and make wiring connections according to state and federal regulations. (Figure 1)
- Use the provided hardware to fasten the end cap to the surface mount. (see instructions for Surface mount)
- Secure the end of the aircraft cables to a structure. Insert each cable's toggle plates into the oval holes located at the top of the fixture box.
*Pull on each cable to make sure the toggle plates are securely in place. (Figure 2)

Figure 1

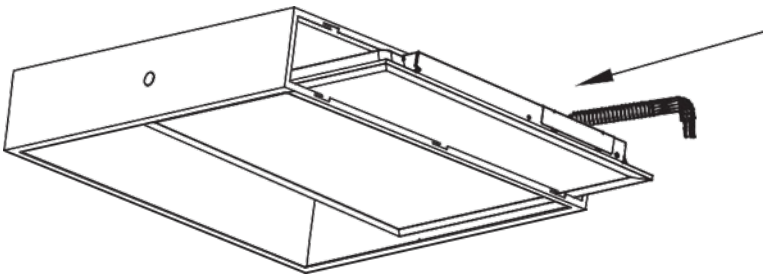
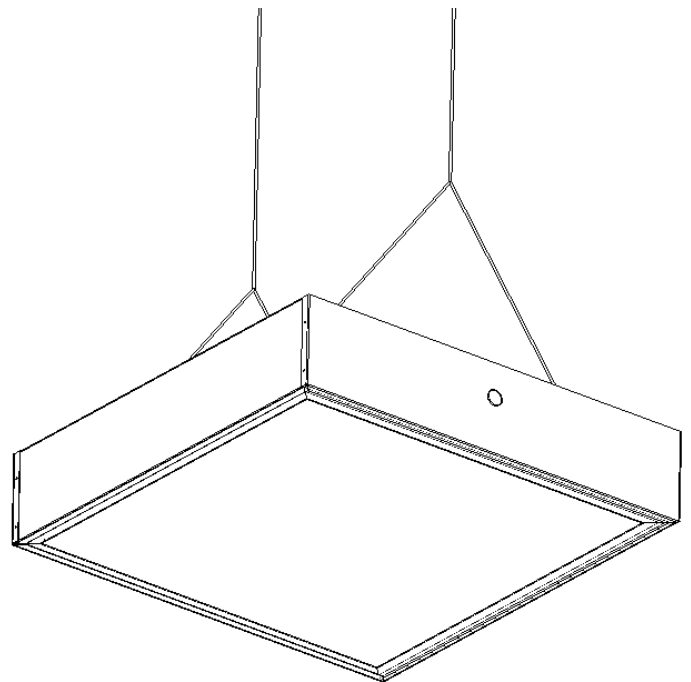
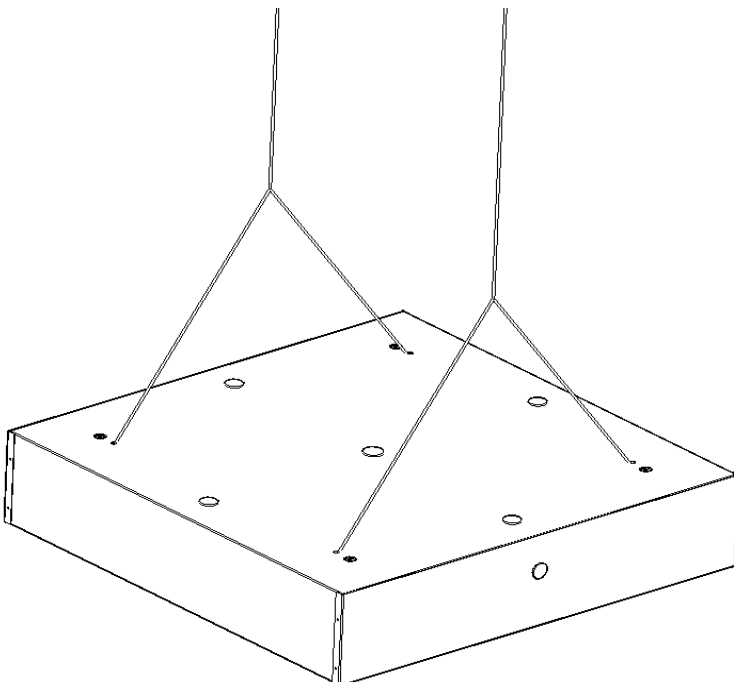
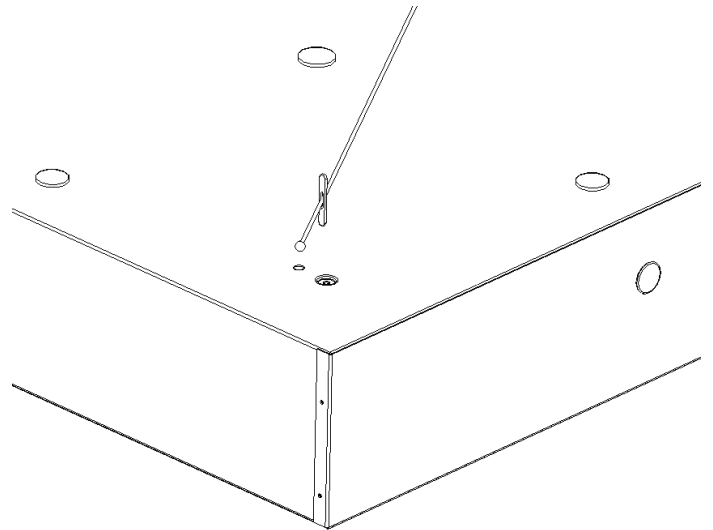

Figure 2





VPAN BACK-LIT PANEL

INSTALLATION INSTRUCTIONS

Additional Accessories – Drywall T-Frame

Parts Checklist:

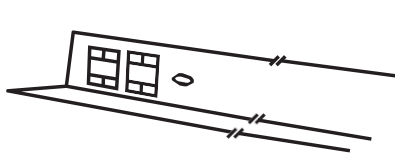

T-Frame Side Support (2)

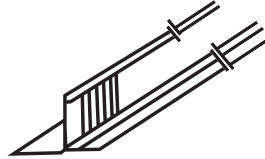

T-Frame End Support (2)

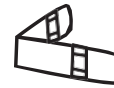

T-Frame Lock Angle (4)

- Insert lock angle into slot on T-frame Support Rail. Tap lock angle into slot until tab locks into place. (Figure 1)
- Insert lock angle into slot on another T-frame Support Rail so they are perpendicular as shown in picture. Tap lock angle into slot until tab locks into place. (Figure 2)
- Repeat 1 & 2 for other 3 corners.(Figure 3)
- Insert assembled T-frame kit into ceiling cavity.(Figure 4)
- Suspend frame from four points using the holes provided on the supports.(Figure 5)
- Wire and insert fixture into ceiling and maneuver into place just as in a grid ceiling to complete installation.(Figure 6)

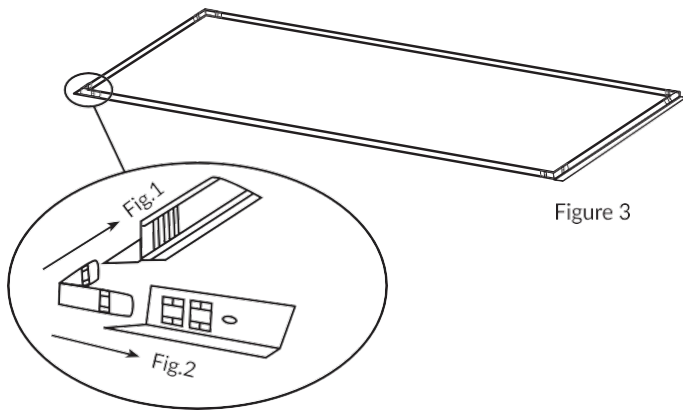

Figure 3

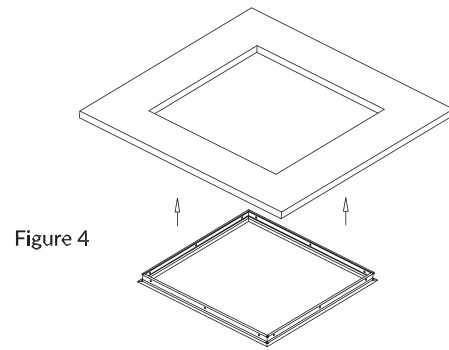

Figure 4

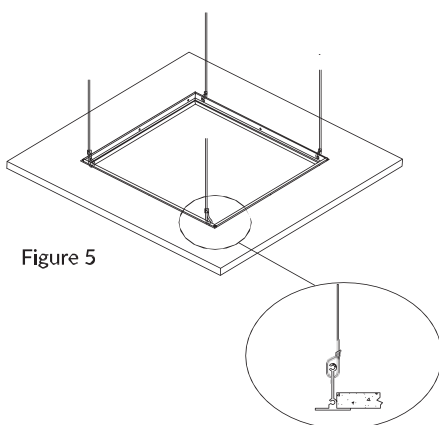

Figure 5

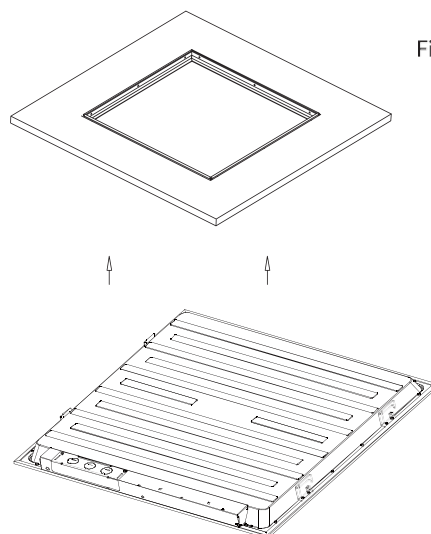

Figure 6



VPAN BACK-LIT PANEL

INSTALLATION INSTRUCTIONS

Additional Accessories - SMSK

Parts Checklist:

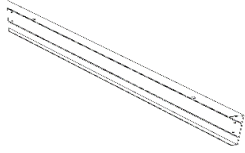

Rails (4)



Screws (16)

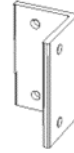

Angle Mounting Bracket (4)

- Attach Angle Mounting Bracket to a rail using screws provided. (Figure 1)
- Repeat this until you have 3 sides all together (Figure 2)
- Position the SMSK at desired location. Hardware no included. (Figure 3)
- Slide fixture partway into the SMSK and make wiring connections according to state and federal regulations (Figure 4)
- Slide fixture fully into the SMSK. Attach last rail to complete installation (Figure 5)

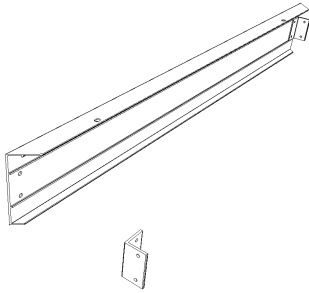

Figure 1

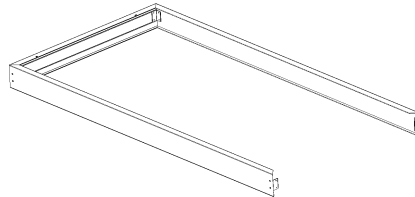

Figure 2

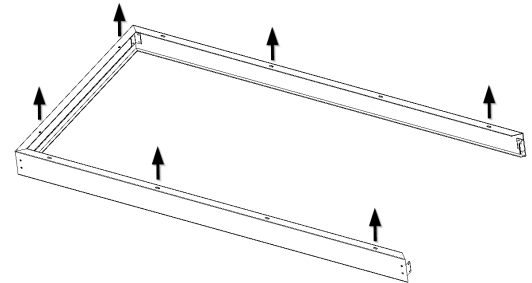

Figure 3

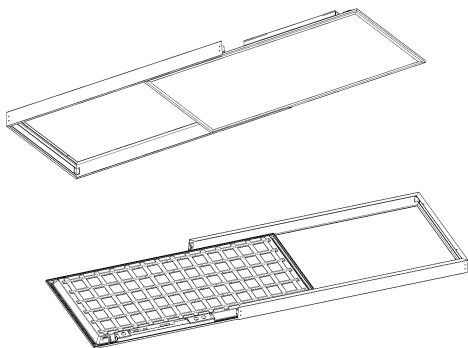

Figure 4

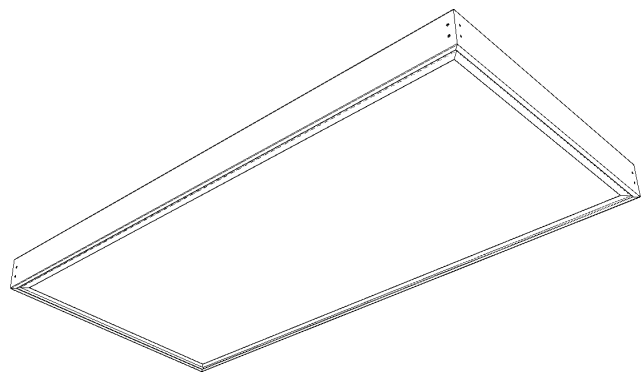

Figure 5



VPAN BACK-LIT PANEL

INSTALLATION INSTRUCTIONS

Field-Adjustable Wattage

The end user may adjust the lumen output (if lumen selectable option is ordered) by the DIP switch integrated into the driver. The DIP switch is accommodated with 3 options which can perform the desired lumen output.

- Factory set to max wattage.
- DIP switch is located on the driver box.
- Select a wattage by sliding DIP switch left or right respectively to the desired value.
- Model VPAN24-66L-U-XX is not wattage selectable

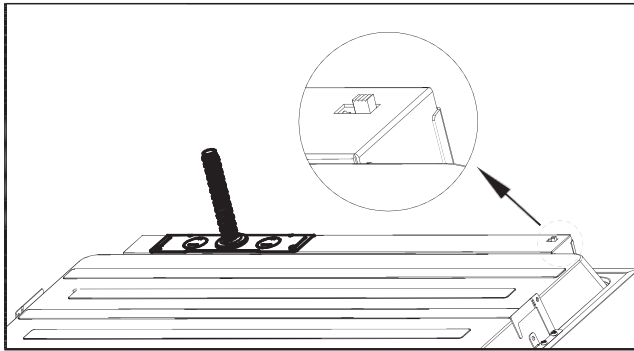

LED Systems Information

Part No.	Input Wattage	Working Current	Voltage	PF	Dimming
VPAN14-22L/27L/33L-U-35	22W-25W-30W	.14-.32 AMP	AC 120-277V 50/60Hz	>0.9	0-10V
VPAN14-22L/27L/33L-U-40	22W-25W-30W	.14-.32 AMP			
VPAN22-27L/33L/44L-U-35	25W-30W-40W	.17-.39 AMP			
VPAN22-27L/33L/44L-U-40	25W-30W-40W	.17-.39 AMP			
VPAN24-33L/44L/55L-U-35	30W-40W-50W	.21-.46 AMP			
VPAN24-33L/44L/55L-U-40	30W-40W-50W	.21-.46 AMP			
VPAN14-22L-U-35	22W	.14-.32 AMP			
VPAN14-22L-U-40	22W	.14-.32 AMP			
VPAN14-27L-U-35	25W	.14-.32 AMP			
VPAN14-27L-U-40	25W	.14-.32 AMP			
VPAN14-33L-U-35	30W	.14-.32 AMP			
VPAN14-33L-U-40	30W	.14-.32 AMP			
VPAN22-27L-U-35	22W	.17-.39 AMP			
VPAN22-27L-U-40	22W	.17-.39 AMP			
VPAN22-33L-U-35	25W	.17-.39 AMP			
VPAN22-33L-U-40	25W	.17-.39 AMP			
VPAN22-44L-U-35	30W	.17-.39 AMP			
VPAN22-44L-U-40	30W	.17-.39 AMP			
VPAN24-33L-U-35	30W	.21-.46 AMP			
VPAN24-33L-U-40	30W	.21-.46 AMP			
VPAN24-44L-U-35	40W	.21-.46 AMP			
VPAN24-44L-U-40	40W	.21-.46 AMP			
VPAN24-55L-U-35	50W	.21-.46 AMP			
VPAN24-55L-U-40	50W	.21-.46 AMP			
VPAN24-66L-U-35	60W	.25-.59 AMP			
VPAN24-66L-U-40	60W	.25-.59 AMP			